

## 50, 100, 150 & 200W LED Floodlights



### Features

- Aluminium housing powder coated black
- Tempered glass lens & polycarbonate cover
- Slim body design
- Constant current driver
- Surge protected 6kV Line-Line, 10kV Line-Earth
- High efficiency SMD chip 125/145Lm/w
- Operating temp: -30°C to +50°C
- IP66 rated at IK08 impact resistance

### Includes

- Prewired 1.5m 3 core cable

CERTIFICATION	IP RATING	DALI DIMMABLE
PROTECTION	IK RATING	BOX   CTN QTY
	 1.7kg @ 300mm	1   1

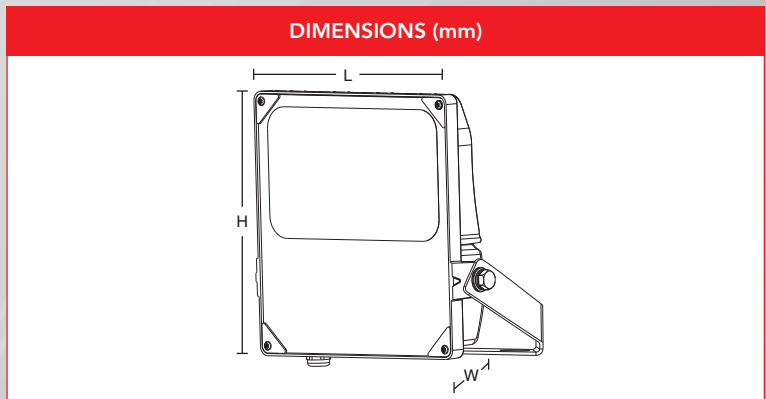

Part No.	Voltage AC	Watt	PF	CCT	Ra	Lumens	Beam Angle	Lifetime hrs	Fitting Colour	Dimensions (L x W x H) mm	Weight
TSFL50W	200-240V	50W	0.95	5000K	70	7,250	120	63,000	Black	228 x 276 x 55	1.8kg
TSFL100W	200-240V	100W	0.95	5000K	70	12,500	120	63,000	Black	314 x 269 x 61	2.8kg
TSFL150W	200-240V	150W	0.95	5000K	70	18,750	120	63,000	Black	360 x 302 x 67	3.9kg
TSFL200W	200-240V	200W	0.95	5000K	70	25,000	120	63,000	Black	398 x 343 x 70	5.3kg

Part No.	Description
TSFL50W	LED 50W Flood Light 5000K Non-Dimmable IP66 7,250 Lumens
TSFL100W	LED 100W Flood Light 5000K Non-Dimmable IP66 12,500 Lumens
TSFL150W	LED 150W Flood Light 5000K Non-Dimmable IP66 18,750 Lumens
TSFL200W	LED 200W Flood Light 5000K Non-Dimmable IP66 25,000 Lumens